

THE WORLD'S LEADING CAD/CAM SOFTWARE COMPANY

That's what we do. That's all we do.

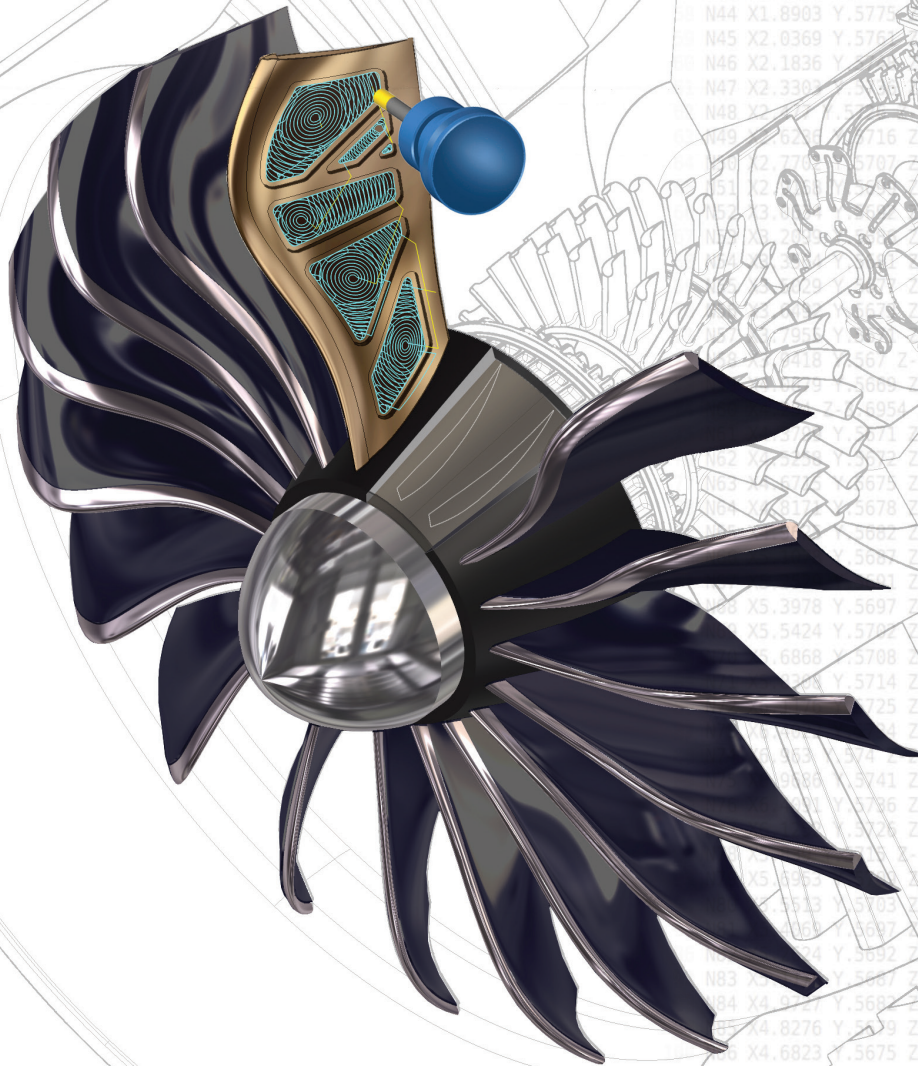

Mastercam®

POWERED BY MASTERCAM'S
DYNAMIC MOTION™ TECHNOLOGY



MILL

LATHE

MILL-TURN

SWISS

WIRE

ROUTER

MASTERCAM for
SOLIDWORKS®

DESIGN

MILL

TRUST THE LEADER FOR SPEED AND CONFIDENCE.

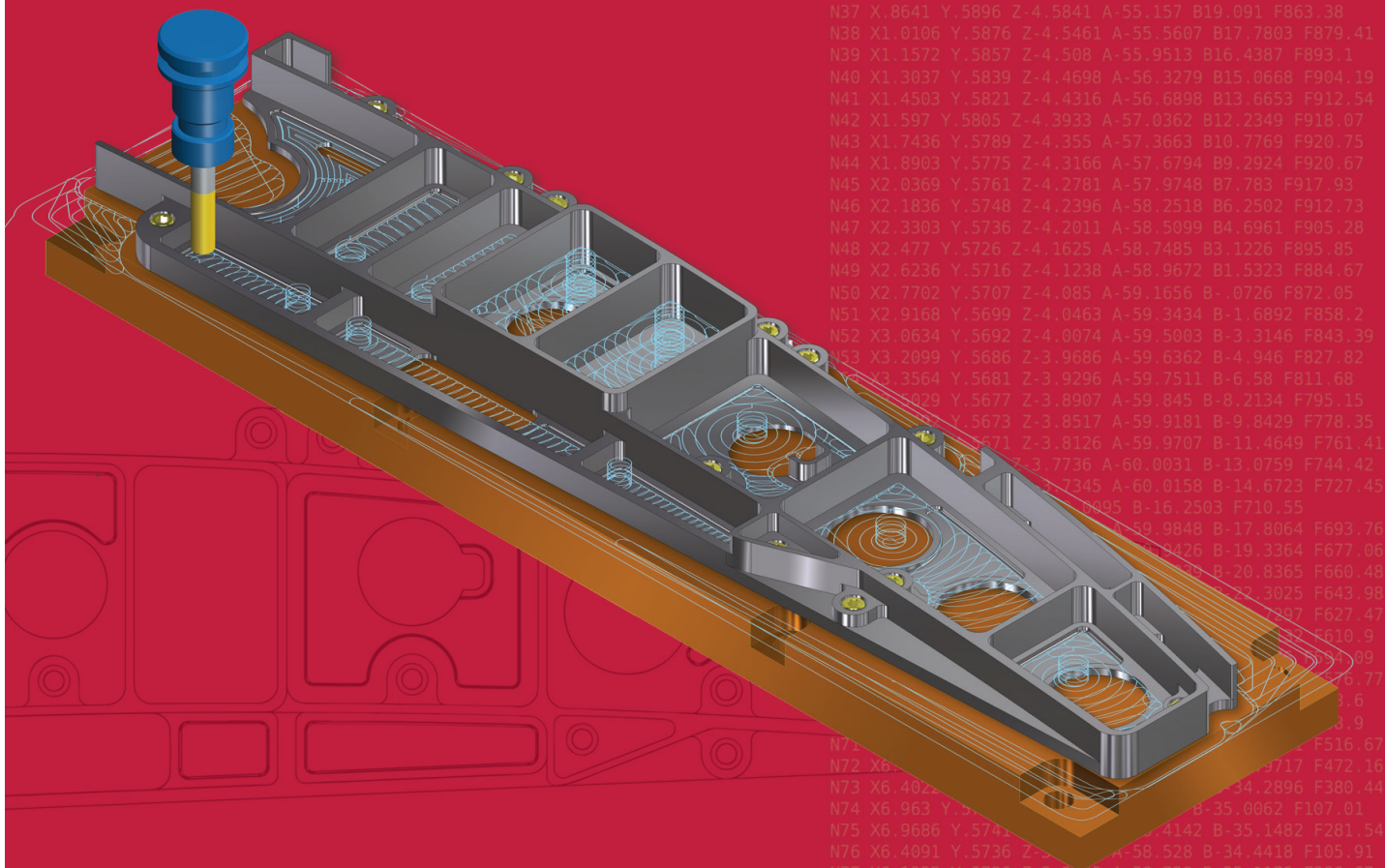

The most widely-used CAM software in the world is the most dynamic. Mastercam's embedded Dynamic Motion technology dramatically shortens production times while extending the life of your machine and tools. Mastercam Mill is rich in features yet still simple and intuitive to use.

Mastercam®

POWERED BY MASTERCAM'S
DYNAMIC MOTION™ TECHNOLOGY



INTELLIGENT MACHINING SAVES TIME AND MONEY.

Since 2008, Mastercam has been building Dynamic Motion into our software.

That means it has been shop-tested and proven in real-world environments. Dynamic Motion toolpaths carve out massive amounts of material quickly — while significantly extending the tool life — immediately putting more money in your pocket. Sounds unbelievable, right? But as the market leader, we've had our Dynamic Motion toolpaths tested in virtually every conceivable work environment around the world. It works.

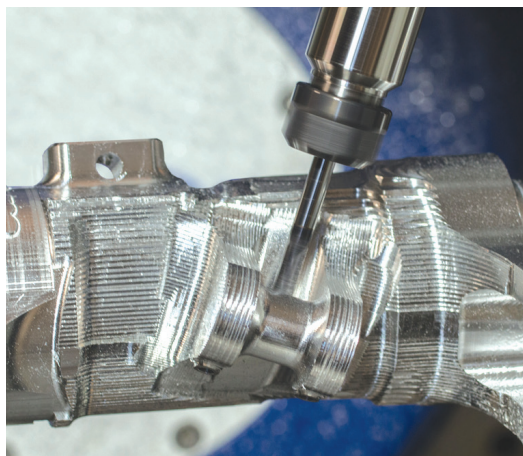

MASTERCAM IS MORE WIDELY USED THAN ANY OTHER CAM PROGRAM

For you, this means some very good things. There's a large and ever-growing base of potential employees already trained and comfortable with Mastercam. More trained, experienced, and Mastercam Certified programmers makes your workforce focused and ready for expansion. Additionally, we are shop-tested. Our software engineers are constantly reaching out to customers to improve and streamline our products. This makes Mastercam the easy choice for the long haul.

Mastercam Mill, including our cutting-edge Dynamic Motion technology, has been shop-tested more than any CAM program in the world. You can count on Mastercam for real-world, tested solutions.

Ultimately flexible and expandable.

Mastercam Mill offers a broad selection of solutions for almost any CNC milling challenge — 2D, 3D, or multiaxis. Whether your industry is automotive or aerospace, medical or consumer products, energy or heavy machinery, Mastercam Mill is ready to help you deliver.

Mastercam's large selection of toolpaths and functions means there's always more than one way to get the job done. Once you program a part, no matter how complex, you can modify any element of the job and immediately get updated toolpaths without starting over. You can also build a library of your favorite machining strategies. Choose any of your saved operations, apply them to a part, and Mastercam helps adapt them to the new model. Because Mastercam Mill is fully integrated CAD/CAM, it's fast, easy, and productive. The way programming should be.

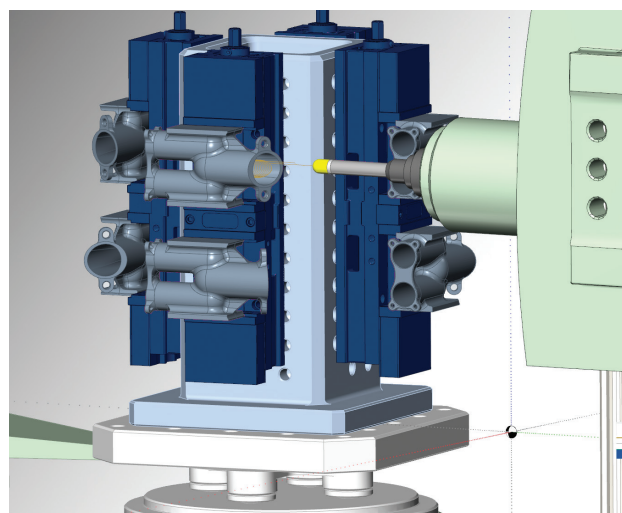

Mastercam's fully associative toolpaths let you efficiently make changes without slowing down. Mastercam Mill's active Stock Model, Toolpath Verification, and Simulation features provide increased confidence on every project. The new Tool Manager delivers a fast, efficient way to create and organize your tooling assemblies.



With your standalone license of Mastercam Mill, you now have the option of also running the corresponding version of Mastercam for SOLIDWORKS.

2D MACHINING

Serious 2D capability.

Your daily needs for 2D machining can range from simple to very complex. Mastercam Mill delivers the tools you need.

- **Feature Based Machining (FBM)** automatically programs prismatic solids drill holes, contours, and pockets. Save or change the strategies at any time.
- Complete and easy control of approach, start points, and entry methods.
- **Contour and pocket remachining** use smaller tools to automatically clean out material left from previous operations.
- Radial chip thinning for a wide set of tools, plus specialized tool support including ISCAR®'s **High Efficiency Machining (HEM)** tool set and more.

Dynamic Motion powers much of our 2D suite, constantly adapting to create smoother, safer motion and making better use of the entire tool. Check out new videos at Mastercam.com to hear it directly from our customers.

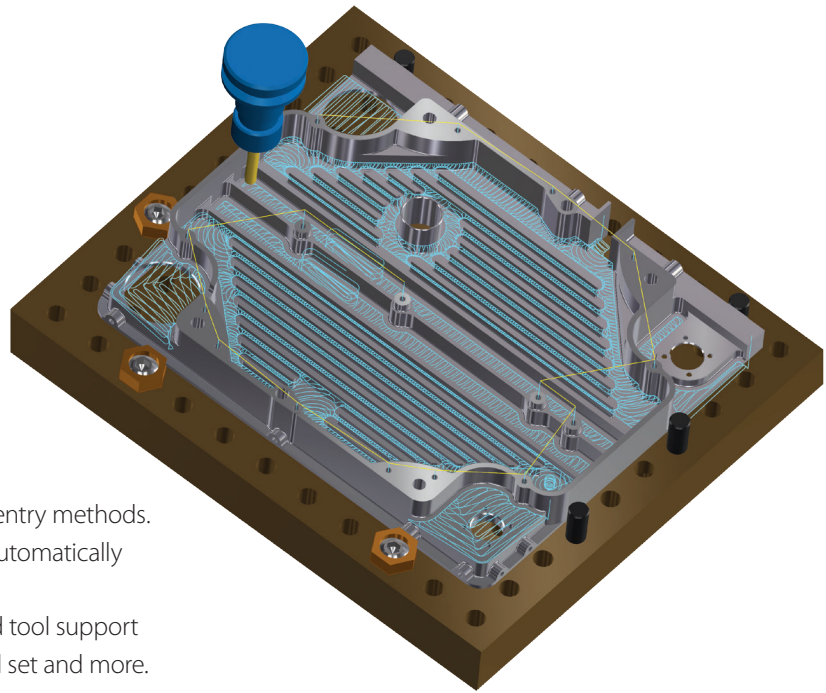

Mastercam's 2D toolpaths deliver easy and optimized pocketing, contouring, drilling, facing, and much more.



The proof of any CAM software is what comes off the machine. Mastercam is crafted to help you get the best possible finish in the shortest amount of time.

3D MACHINING

Our finish is more finished.

Mastercam's extensively shop-tested 3D toolpaths provide unsurpassed control on surface cuts, delivering superior finishes and optimized cycle times. Our smart **hybrid finishing** creates a single toolpath that changes cut methods as the slope of the model changes. And our refined 3D toolpaths give you the smooth, precision finish to please even your toughest customers.

- Cut multiple surfaces, solid models, and mesh entities (STL data).
- **Dramatically efficient roughing** powered by Mastercam's Dynamic Motion technology.
- Constant scallop machining maintains a consistent finish on sloped and flat surfaces alike by using a consistent 3D stepover.
- Constant-Z rest milling (remachining) identifies and machines areas and critical depths that need to be cut with a smaller tool.
- **Pencil tracing** walks a tool along the intersection of surfaces to clean out hard-to-reach areas. Single or multiple passes deliver precision cleanup.

MULTIAXIS MACHINING

Complexity simplified.

Multiaxis machining can dramatically increase a shop's competitiveness. Mastercam's multiaxis interface is surprisingly simple and intuitive to use, ensuring any shop can make the move when the time is right. With Mastercam, you have complete control over the three crucial elements of multiaxis machining: cut pattern, tool axis control, and collision avoidance. From 4-axis rotary and roll die cutting to multiblade impellers with tight internal cuts, Mastercam helps simplify even the most complex jobs.

Other highlights include:

- **Multisurface 5-axis** roughing and finishing (including depth cuts), plunge roughing, and flowline machining.
- Swarf machining over multisurface floors.
- **Advanced gouge checking**, a "safe zone" around the part, and safe linking between operations.
- Fast, simple 5-axis trimming and stock-aware drilling.
- Ability to create full 5-axis motion from a 3-axis toolpath.

For specialty machining, ask about these available Add-Ons:

- **Mastercam Blade Expert** delivers specialized tools for efficiently cutting multi-bladed parts and hubs.
- **Mastercam Port Expert** offers smoother toolpath motion and dramatically faster programming for head ports and tube-type applications.



From basic 5-axis contours to Dynamic roughing and complex finishing, Mastercam is built to streamline multiaxis programming.

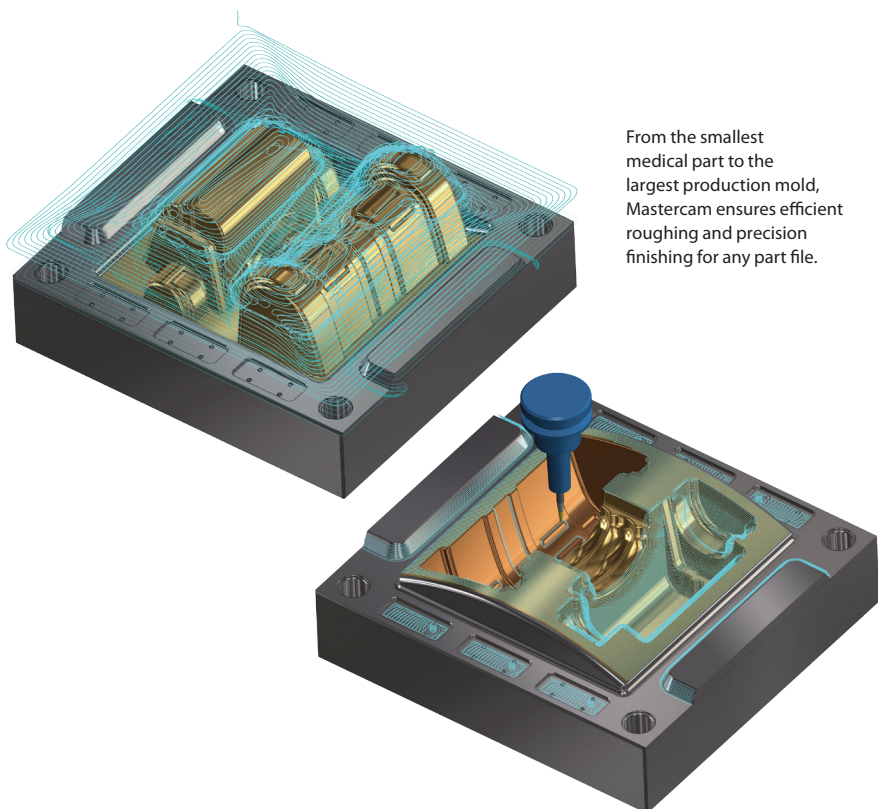

From the smallest medical part to the largest production mold, Mastercam ensures efficient roughing and precision finishing for any part file.

TIME AND MONEY

100 Hastelloy parts cut with and without Dynamic toolpaths.

| Without | With |
|---|---|
| 5 hours | 40 minutes |
| 10-15 inserts (12.5) per part | 1.5 inserts per part |
| 5 hr. x \$100/hr. = \$500 | 40 min. x \$100/hr. = \$66 |
| 12.5 inserts @ \$25 = \$312.50 | 1.5 inserts @ \$25 = \$37.50 |
| \$812.50 per part x 100 parts = \$81,250 | \$103.50 per part x 100 parts = \$10,350 |

Real world savings of 87%!

For more information, visit MastercamMill.com