

THE WORLD'S LEADING CAD/CAM SOFTWARE COMPANY

That's what we do. That's all we do.



Mastercam®

POWERED BY MASTERCAM'S
DYNAMIC MOTION™ TECHNOLOGY



MILL

LATHE

MILL-TURN

SWISS

WIRE

ROUTER

MASTERCAM for
SOLIDWORKS®

DESIGN

MILL-TURN

RUN WITH CONFIDENCE. RUN WITH PRIDE.

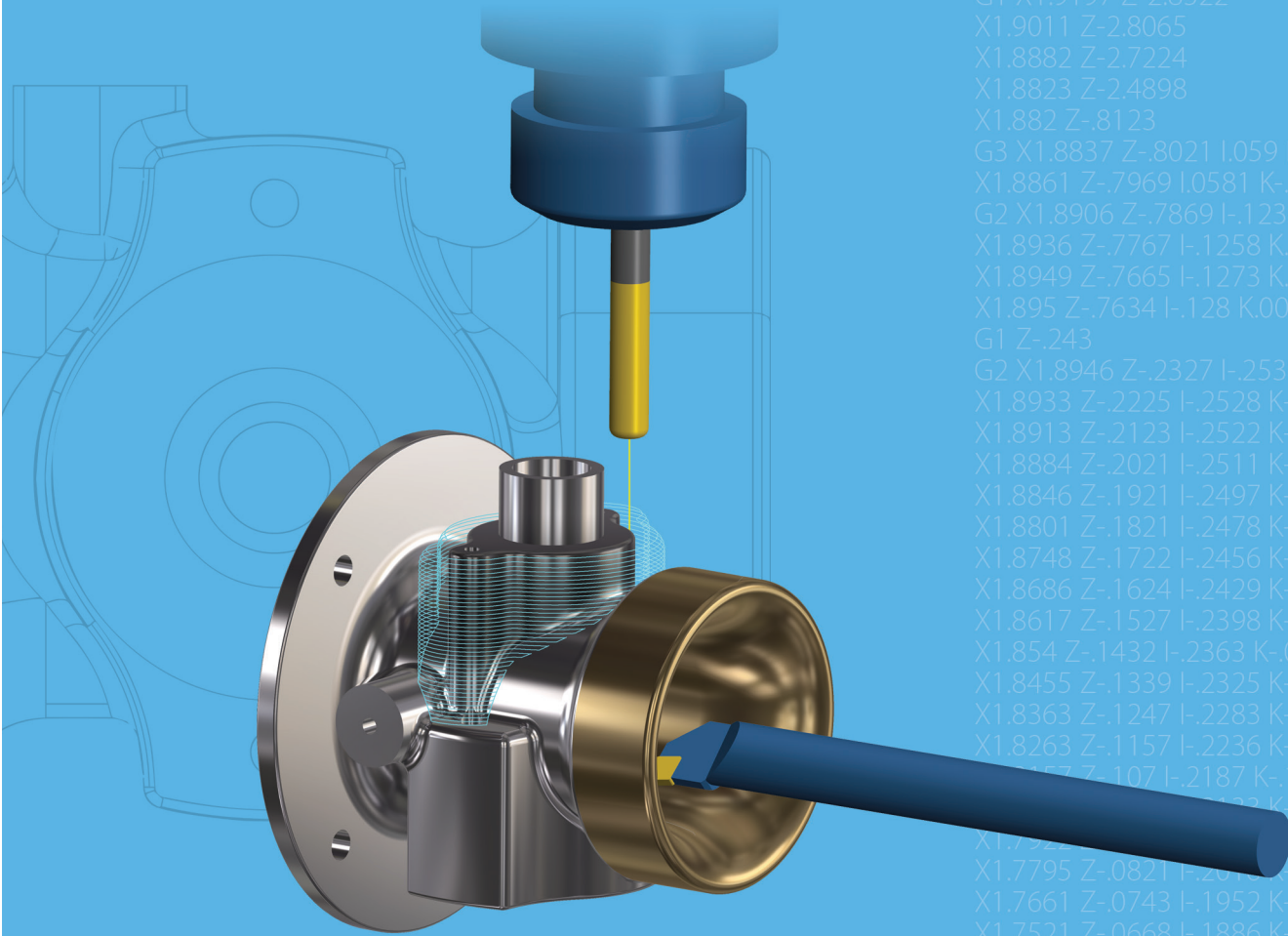

G2 X1.9428 Z-2.8662 I.059 K0.
X1.9481 Z-2.8761 I.0581 K.0102
X1.9567 Z-2.8854 I.0555 K.0201
X1.9607 Z-2.8886 I.0512 K.0294
G3 X1.9712 Z-2.8974 I.0993 K-.0653
X1.9993 Z-2.9395 I-.1026 K-.0582
G2 X2.0129 Z-2.9422 I.0146 K.002
X2.0542 Z-2.9451 I0. K.0147
X2.0585 Z-2.9375 I-.0126 K.0077
X2.0411 Z-2.9241 I-.0148 K0.
G1 X2.0039 Z-2.9154
G3 X1.9757 Z-2.9017 I.0123 K.0268
G2 X1.9603 Z-2.8884 I-.1058 K-.0523
X1.9482 Z-2.8801 I-.0982 K-.0655
X1.9381 Z-2.8742 I-.0921 K-.0738
G1 X1.9197 Z-2.8522
X1.9011 Z-2.8065
X1.8882 Z-2.7224
X1.8823 Z-2.4898
X1.882 Z-.8123
G3 X1.8837 Z-.8021 I.059 K0.
X1.8861 Z-.7969 I.0581 K-.0102
G2 X1.8906 Z-.7869 I-.1235 K.0335
X1.8936 Z-.7767 I-.1258 K.0235
X1.8949 Z-.7665 I-.1273 K.0134
X1.895 Z-.7634 I-.128 K.0031
G1 Z-.243
G2 X1.8946 Z-.2327 I-.253 K0.
X1.8933 Z-.2225 I-.2528 K-.0103
X1.8913 Z-.2123 I-.2522 K-.0205
X1.8884 Z-.2021 I-.2511 K-.0307
X1.8846 Z-.1921 I-.2497 K-.0409
X1.8801 Z-.1821 I-.2478 K-.0509
X1.8748 Z-.1722 I-.2456 K-.0609
X1.8686 Z-.1624 I-.2429 K-.0708
X1.8617 Z-.1527 I-.2398 K-.0806
X1.854 Z-.1432 I-.2363 K-.0903
X1.8455 Z-.1339 I-.2325 K-.0998
X1.8363 Z-.1247 I-.2283 K-.1091
X1.8263 Z-.1157 I-.2236 K-.1183
X1.8177 Z-.107 I-.2187 K-.1273
X1.8092 Z-.102 K-.136
X1.7922 Z-.11446
X1.7795 Z-.0821 I-.2018 K-.1529
X1.7661 Z-.0743 I-.1952 K-.1609
X1.7521 Z-.0668 I-.1886 K-.1687
X1.7376 Z-.0596 I-.1816 K-.1762
X1.7224 Z-.0527 I-.1743 K-.1834
X1.7067 Z-.0461 I-.1667 K-.1903
X1.6935 Z-.0400 I-.1589 K-.1969
X1.6738 Z-.0339 I-.1507 K-.2032
X1.6589 Z-.023 I-.1338 K-.2147
X1.6209 Z-.0101 I-.1125 K-.22
X1.6025 Z-.0136 I-.116 K-.2249
X1.5837 Z-.0095 I-.1067 K-.2294
X1.5801 Z-.0087 I-.0974 K-.2335
G2 X1.5261 Z-.0069 I.0223 K.0546
G1 Z-.05
G3 X1.5044 K.039
059 K0.
Z-.6069
G1 Z-.6266
X1.9655 Z-.6968
X1.9612 Z-.7161

The most widely-used CAD/CAM software in the world gives you the confidence to automate your complex programs on today's high-powered, multi-streamed, multitasking machining centers. Program it right the first time, every time.

Mastercam®

POWERED BY MASTERCAM'S
DYNAMIC MOTION™ TECHNOLOGY



MASTERCAM MILL-TURN SIMPLIFIES YOUR MOST COMPLICATED PROJECTS.

Mastercam Mill-Turn simplifies today's high-powered, multi-stream machining centers.

Mill-Turn delivers the best in shop-tested cutting techniques combined with the latest in machine and toolpath management and verification.

Your workflow is easy. Choose your machine and Mastercam Mill-Turn automates part transfers, toolplanes, stock definition, and setup. Then apply your toolpaths and syncing, verify your project with simulation, and post your code. Changes along the way are fast and easy — the way programming should be.

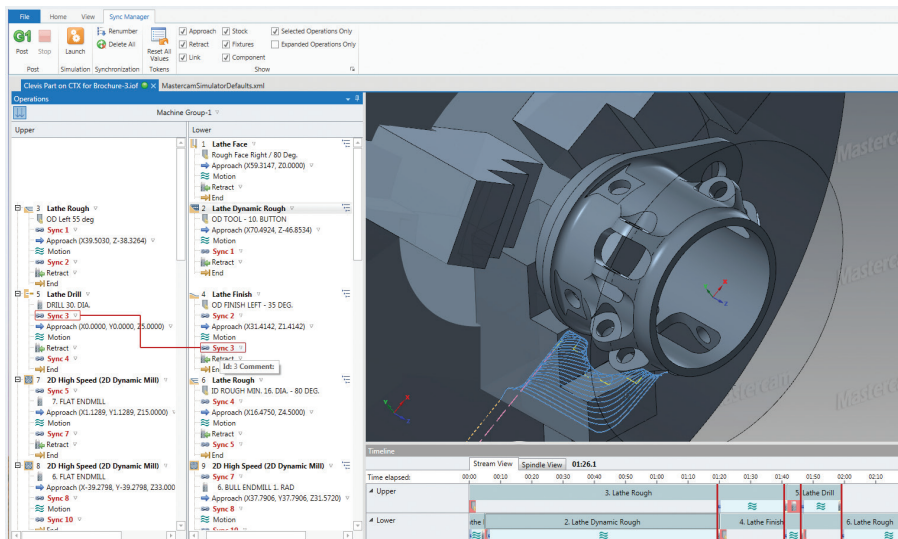

Get the most out of your machines with Sync Manager.

Mill-Turn's Sync Manager is a user-friendly way to optimize part cycle times and avoid collisions before your part ever reaches the machine. Mill-Turn has the option for unlimited streams where you can easily sync operations to your liking. Easily navigate our Gantt-style timeline and vertical stream interface to coordinate operations and track cycle time estimates.

See it's right. Know it's right.

Simulation provides you with the ability to safely and confidently run your job on your machine environment virtually before it reaches the shop floor. All of your machine's components and your project's machined stock are run from the safety of your desktop, ensuring a safe and secure machining experience. You can identify potential collisions, and explore ways to optimize your processes with simulation. Also, you will be able to view all streams and statistics of the entire machining process, and have the capability to jump to any point in the machining process with the click of a button.

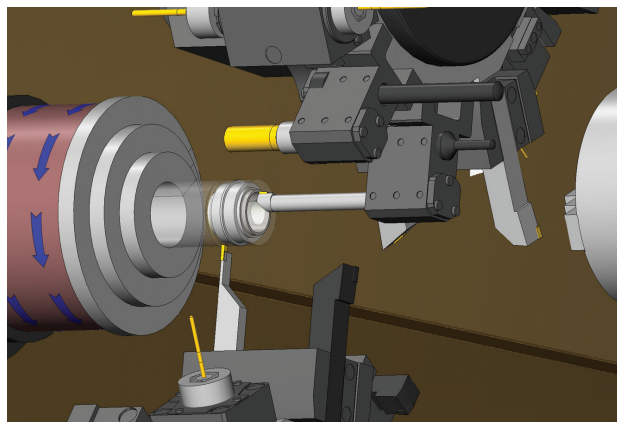

Get the most from your machine with multi-station and half-index tool support.

For more information, visit MastercamMillTurn.com